

IS COMPUTERIZED SHOTCRETING A POSSIBILITY? ...
... IT'S A REALITY.

By Mike Rispin, P.Eng.
Director, Underground Construction and Allentown Equipment
Master Builders, Inc.

Any nozzleman who, at some point in his or her career, has made a first transition from hand nozzling to using a robotic arm, knows the value in use that mechanical technology has brought to our industry. Far beyond just saving human backs and arms during a shift of spraying concrete, robotic arms (booms, lances, etc.) have taken the application of shotcrete to the next level, facilitating rapid deployment of material to significant thicknesses, in hard-to-reach areas, particularly in the underground construction environment (tunnels or mines).



Figure 1. Master Builders' MSV Mining Spraymobile

This quantum leap in technology, while nonetheless requiring training and skill to operate, makes shotcreting easier.

But what if those human factors that, unbidden but inevitably, detract from the quality of an in-place shotcrete could be controlled or eliminated? They can be ...

A new machine, based on the well known kinematic principles of the MEYCO-Robojet, has been developed in cooperation with industry and academia. This manipulator with eight degrees of freedom has a new automatic and human oriented control system. The new tool enables an operator to manipulate the spraying jet in various modes, from purely manual to semi-automatic and fully automatic, within selected underground areas. The technology that makes this possible is known commercially as the Meyco Logica Control System.

MEYCO ROBOJET LOGICA

The Meyco Robojet Logica is a computer controlled concrete spraying robot manipulator, designed for the civil tunnelling and underground mining industries. The Robojet Logica (See Figure 2) is based on the proven kinematic principle of the Meyco Robojet. The manipulator is equipped with motion control, which is software controlled and programmable.



Figure 2 Meyco Robojet Logica

The Robojet Logica manipulator, with its eight degrees of freedom, is equipped with the necessary sensors at each joint to record the absolute position of each joint with respect to the next, and report this to the main computer. The Robojet Logica also has the ability to scan and map the working area. To measure the tunnel dimensions and determine its work envelope, the lance head has been fitted with a scanner laser system.

The Robojet Logica is capable of operating in three modes of operation. These are: manual, semi-automatic, and automatic.

Manual mode operation of the Robojet allows the operator to manipulate the spraying nozzle using a single “space” joystick. The space joystick allows the operator to point the nozzle in the correct location to spray the concrete (See Figure 3). The operator does

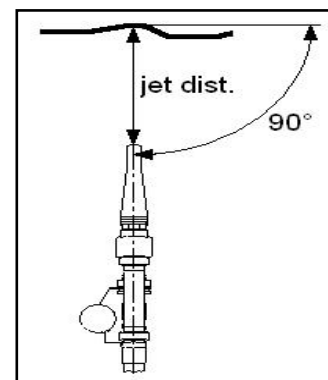

Figure 3 Operator console for the Logica

Figure 4 Stand-off distance and nozzle angle

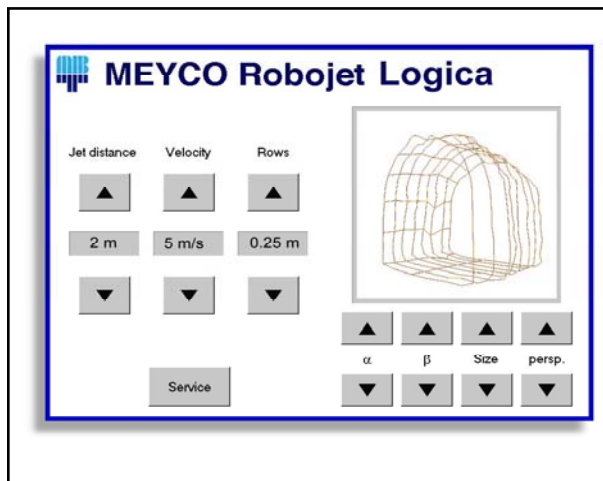

Figure 5 Logica PC control panel

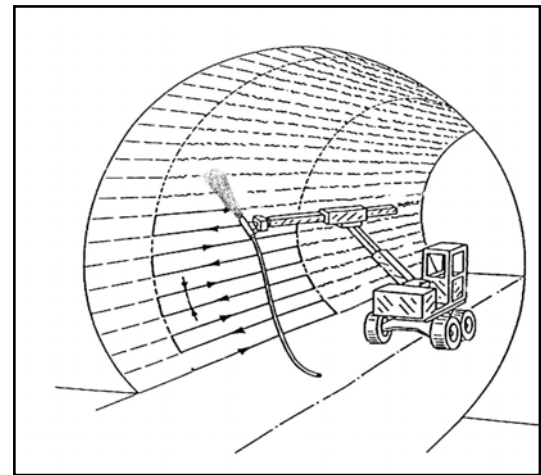

Figure 6 Row distance

not need to be preoccupied with positioning the manipulator's joints while spraying. The result is simplified training and a shorter learning period for operating the Robojet. The semi-automatic mode allows the operator to control the movement of the nozzle along the walls of the drift. The computer (Logica) controls the standoff distance and the angle of the spraying jet through the software (See Figure 4). To be able to control these two spraying parameters, the laser scanner is used to create a three-dimensional work envelope in the computer (See Figure 5). The computer uses this three-dimensional grid to calculate the perpendicular position of the nozzle and the spraying angle of the nozzle.

The Robojet Logica also has the capability of operating in automatic mode. The computer controls nozzle distance, nozzle angle and the velocity of the jet along the surface of the rock. The laser scanner is used the same way as the semi-automatic mode. The machine then performs the spraying process automatically. The speed of the nozzle along the rock surface, and the row distance remain constant (See Figure 6).

TECHNOLOGICAL ADVANTAGES

In semi-automatic mode, the computer takes two of the key parameters of quality shotcreting out of the nozzleman's hands; namely, a constant perpendicularity to the substrate and a constant, ideal standoff distance. The result is optimum compaction of the shotcrete on the substrate and dramatically reduced rebound.

Going one step further, automatic mode further facilitates the placement of a constant thickness of shotcrete, regardless of substrate irregularity. This dramatically reduces the extra cost of extraneously placed shotcrete, while ensuring that the minimum cover is uniformly attained. In short, the in-place shotcrete, with a modicum of preparation, closely matches the ground support specification.

PRACTICAL EXPERIENCE

In 1998, Inco Limited in Sudbury, Canada acquired a prototype of the Meyco Robojet Logica and, through a cooperative practical research and development program with Master Builders, assessed and further developed the Logica Control System through to its current commercial form.

The Logica was evaluated in Inco's 176 Orebody, an underground research mine, in an environment closely approximating that of an operating, developing and producing mine. At the conclusion of the test period, the following conclusions were drawn:

- The Logica demonstrated control of the spraying operation by applying a specified thickness of concrete to a mine opening
- Logica technology demonstrated repeatability in the spraying process by spraying concrete to a mean thickness of 2.60 inches \pm 0.4 inches over multiple rounds
- Results indicated that spraying concrete with Logica technology can reduce rebound to approximately 3.6%, however, an average value of 5% can be expected
- The operator monitored the operation as opposed to controlling the operation
- Operation with the Logica is safer than conventional methods
- The amount of dust in the working area was reduced
- Shotcrete application was less laborious than with conventional wet application methods

THE PATH FORWARD

At the time of writing of this article, Inco's Robojet Logica had been moved to their producing Stobie Mine, where it will be used for shotcrete application, on an ongoing basis, in rehabilitation and development work areas.

Meyco's work with the Logica is focusing on the application of shotcrete final linings in tunnels, as well as the application of passive fire resistant linings.

Logica technology provides many of the advanced capabilities that the shotcrete industry has identified as critical. The economic and other benefits become rapidly apparent with use, making the payback on the up-front capital investment an attractive one.

REFERENCES

Tschumi, O.; "Automated Shotcrete Application"; Canadian Institute of Mining Annual General Meeting; Montreal, QC, Canada; 1998.

Rispin, M., N.Runciman and B.Knight; “Shotcrete Research and Development at Inco’s Test Mine”; Third International Conference on Sprayed Concrete; Gol, Norway; 1999.

Runciman, N., S.Espley and M.Rispin; “Testing and Evaluation of the Meyco Robojet Logica at INCO Limited”; Telemin Conference; Sudbury, ON, Canada; 1999.

Runciman, N.; “Automated Ground Support Technology at Inco – Meyco Robojet Logica”; Inco Report; Sudbury, ON, Canada; 2000