

MASTERFLEX[®] AQUASTOP

Centrally and externally placed PVC Waterstops

Description

MASTERFLEX AQUASTOP is a range of centrally placed and externally placed PVC Waterstops extruded from high grade PVC compound.

Primary uses

MASTERFLEX AQUASTOP is designed to provide a complete sealing network for expansion and contraction/ construction joints in water retaining and water excluding in-situ concrete structures. The profiles are supplied in straight lengths to be butt jointed on site. Factory made intersections are available for complex junctions. The use of MASTERFLEX AQUASTOP prevents the passage of water through expansion/ contraction/ construction joints in the following typical structures:

- Canals/ culverts
- Water tanks
- Reservoirs
- Dams
- Sewerage Treatment Plants
- Liquid retaining vessels
- All cast in-situ concrete structures to retain or exclude water

Advantages

- Complete range of profiles and sizes to suit all construction requirements.
- Reinforced eyeleted fixing flanges on centrally placed profiles for positive location in joints prevents collapse of profile during concrete placing.
- Simple on-site butt welding.
- Four valve sealing system on all profiles.
- Premoulded intersection/ junction pieces available.

Design considerations

PVC Waterstops were originally designed as simple dumbbell profiles which worked on the valve sealing action of the opening joint putting the waterstop in tension, thus sealing the water path. Later designs included multi ribs and fins, in what is known as the tortuous path principal of an extended potential water track created by the ribs and fins.

MASTERFLEX AQUASTOP combines all the accepted and proven principals of PVC Waterstop in four valve and tortuous path design, together with reinforced eyeleted fixing flanges on all centrally placed profiles plus grout check fins on all construction/ contraction joint profiles.

Technical data

*Typical Properties

Form:	Extruded PVC
Solids content:	100%
Colour:	Blue
Tensile strength:	15 N/mm ² Minimum
Elongation at break:	350% Minimum
Shore 'A' Hardness:	75° – 80°
Toxicity in potable water:	None
IEJ/ EEJ Extension:	15 mm
IEJ/ EEJ Transverse Shear:	25 mm
ICJ/ ECJ Extension:	6 mm
Alkali resistance:	Pass
Hydrocarbon resistance:	Pass

MASTERFLEX[®] AQUASTOP

Standards

- ASTM D 638 : 91 (Tensile/ Elongation)
- US Corps of Engineers CRD-C572-74 (Alkali Resistance)
- BS 6920 (Toxicity)
- Instron Tensometer (Extension/ Transverse Shear)

Profiles

Centrally placed MASTERFLEX AQUASTOP profiles provide a barrier across all joints in-situ concrete structures by casting the section centrally into the edges of adjacent concrete components. Used in most water retaining and water excluding structures, they are capable of withstanding water pressure from either the internal or external face.

MASTERFLEX AQUASTOP IEJ (Internal Expansion Joints): Expansion bulb sections principally for expansion joints but can be used for construction/ contraction joints. With reinforced eyeleted fixing flanges for wiring the waterstop to surrounding rebar.

* EYELET

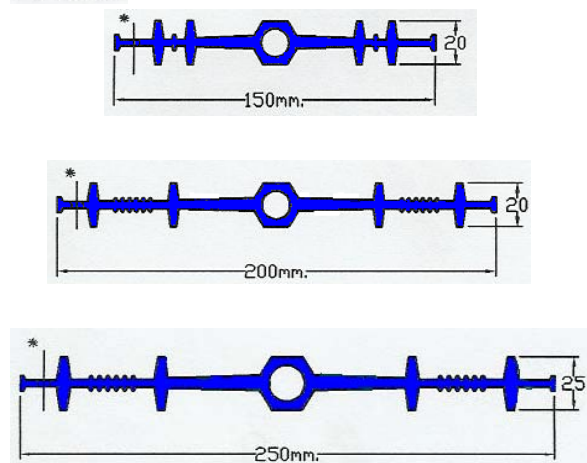

MASTERFLEX AQUASTOP ICJ (Internal Construction/ Contraction Joints): Plain web sections for construction/ contraction joints, also with reinforced eyeleted flanges and grout check fins to prevent grout loss from formwork.

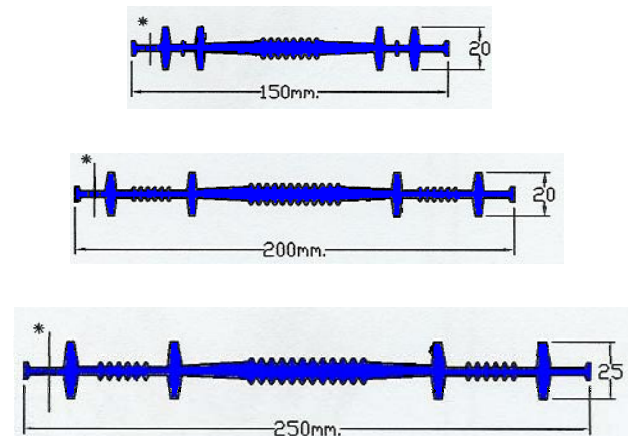

Externally placed MASTERFLEX AQUASTOP profiles are principally designed for basement, foundation and floor slab applications in both vertical and horizontal joints.

Each externally placed section incorporates a reinforced railing flange for fixing to the formwork or blinding concrete. The four valves allow good concrete compaction and very secure anchorage into the concrete.

MASTERFLEX AQUASTOP EEJ (External Expansion Joints): Sections have a flat top, wedged expansion box for positive anchorage and good seating of joint fillers. EEJ sections can also be used in construction/ contraction joints. The bottom web in the expansion box is thinned to cater for excessive subsidence or seismic movement should it occur.

MASTERFLEX[®] AQUASTOP

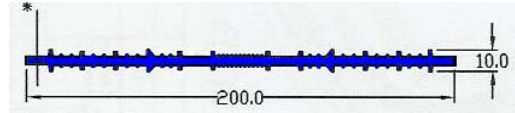
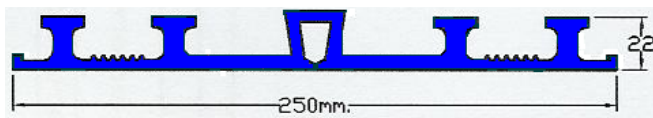
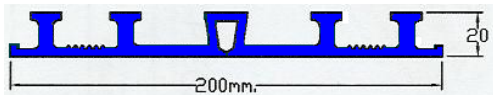
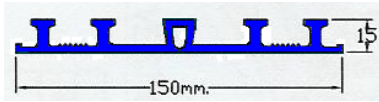

MASTERFLEX AQUASTOP 250 ICJ/X & 250IEJ/X Are 10mm thick web profiles for applications where there is high water pressure or head of water in excess of 70 meters. Both profiles include reinforced eyeleted fixing flanges and are compatible with 250 ECJ/ EEJ profiles in an integral network.

MASTERFLEX AQUASTOP ECJ (External Construction / Contraction Joints): Sections are plain web incorporating grout check fins to prevent grout loss at formwork.

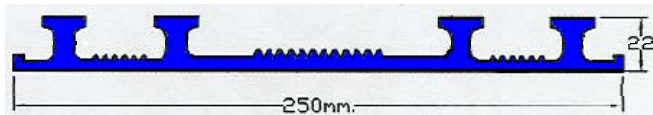
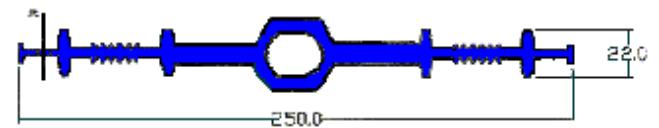
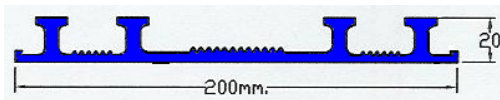
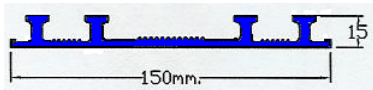
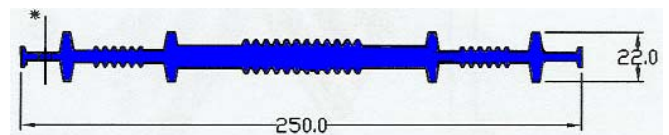

Waterstop selection

MASTERFLEX AQUASTOP PVC Waterstops are designed for use within the performance parameters indicated under the headings Technical Data and Typical Properties.

Special Profiles

MASTERFLEX AQUASTOP 200M ICJ/E is an economic construction/ contraction joint profile specifically for use in kicker and contraction joints in small structures such as water tanks cast in-situ manholes, channels etc where there are no expansion joints and wall or slab thicknesses do not exceed 200mm. Includes an eyeleted flange.

Centrally placed profiles (ICJ & IEJ) are usually located midway in the slab or wall thickness across the joints in concrete structures. They will equally prevent the passage of water through the joint from either face.

They are particularly suited to water retaining structures and in walls and slabs where pressure differential may occur such as in reservoir walls. They are equally appropriate for joints in suspended slabs, vertical wall joints and lift joints.

MASTERFLEX[®] AQUASTOP

Externally placed profiles (ECJ & EEJ) are of particular advantage for their ease of installation in basement and foundation applications in situations where they are firmly supported against back pressure, i.e. in water retaining structures (base slab) where they are placed on the blinding concrete.

Size of waterstop

The choice of width of profile is mainly governed by slab/ wall thickness, position of reinforcing steel and aggregate size. As a general rule, the 250mm width profiles are appropriate for slab/ wall thickness over 250mm, allowing good compaction and width of barrier to water penetration. For concrete members less than 250 mm the use of a smaller profile approximating to the actual slab or wall thickness will be appropriate.

Installation

MASTERFLEX AQUASTOP ICJ & IEJ profiles must be installed so they are securely held in the correct position whilst the concrete is poured. The concrete must be fully and properly compacted around the waterstops (the use of BASF's Rheodynamic admixtures to produce self compacting concrete is of great advantage to avoid voids or porous areas after concrete placing). Where reinforcement is present, an adequate clearance must be left between this and all waterstops to permit proper compaction of the concrete.

The eyelets in the reinforced flanges of the ICJ and IEJ profiles allow them to be wired to the surrounding reinforcing steel. The eyelets are an integral part of the profiles and being placed outside the outer valves cannot create a water

path around the profile or impair the efficiency in performance in any way. See typical detail below.

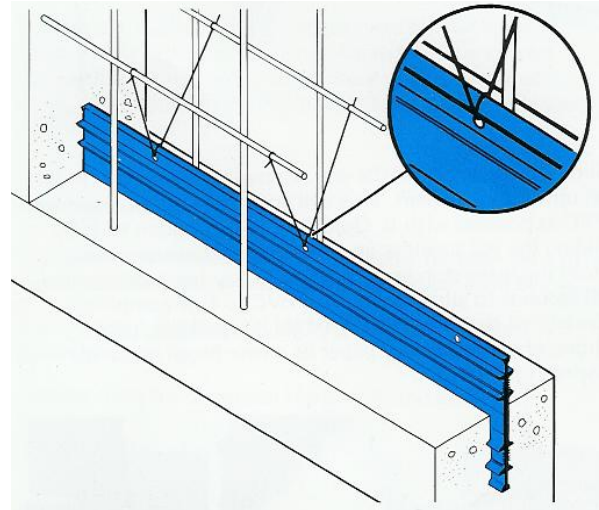

MASTERFLEX AQUASTOP ECJ & EEJ profiles when used on ground slab blinding concrete where a permanent, firm and stable support is given usually require no fixing. The profile is simply laid centrally over the line of the joint to be formed. Fixing to vertical shuttering is simplified by nailing with double headed nails through the outer reinforced flange to provide a firm fixing as shown below.

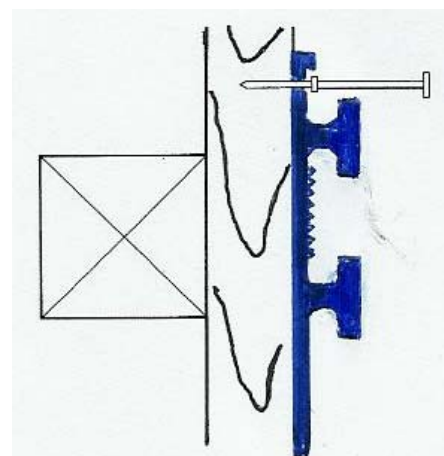



The Chemical Company

MASTERFLEX[®] AQUASTOP

Equipment

Heat welding equipment is available to enable site jointing to be carried out efficiently. Jointing jigs ensure that the mating surfaces of the waterstop are accurately aligned while the heater blade heats the waterstop to the necessary temperature for jointing.

Jointing Jigs

150mm AQUASTOP	EEJ/ ECJ
200mm AQUASTOP	EEJ/ ECJ
250mm AQUASTOP	EEJ/ ECJ
150mm AQUASTOP	IEJ/ ICJ
200mm AQUASTOP	IEJ/ ICJ/ ICJ/ E
250mm AQUASTOP	IEJ/ ICJ/ ICJ/ X

220 Volt Electric Heater Blades for use with all jigs.

Site Jointing Instructions

Reliable jointing of MASTERRLEX AQUASTOP waterstops can be carried out rapidly onsite with AQUASTOP heat welding equipment. Complete welding kits, comprising simple jigs and electric blades, are available and provide all that is needed to make tough joints between all PVC waterstop sections, Note that when ordering MASTERFELX AQUASTOP equipment, both the type and width of waterstop must be stated.

Heat welding of AQUASTOP Waterstops:

Make sure that the heater blade is clean, plug it into the correct voltage electricity supply and leave in a safe position to warm up.

Ensure that the ends of the waterstop to be jointed are of the same width and profile; clean them with water or CLEANING SOLVENT NO. 2 and dry them.

Clamp them in the correct profile slots of the jig provided and cut both ends off square with a sharp knife, flush with the faces of the jig.

Note: An allowance must be made for waste and for the 5 to 10mm that will be taken up by melting when calculating the length of waterstop required.

Loosen the jig and slide them back so that approximately 10mm of each waterstop end projects and then clamp the jig tightly in position.

Position the heater blade on the bars between the jigs and slide them together until the waterstop ends are pressed firmly against the sides of the blade. The PVC should melt without burning or charring. Hold the jig firmly in position until a bead of molten PVC approximately 3mm in diameter appears along either side of the heater blade.

Slide the jig apart a little and remove the heater blade with an upward movement. This will ensure that it takes as little PVC as possible with it. Quickly joint the molten ends by sliding the jig together and exerting pressure. Approximately 20 seconds to allow the molten PVC to fuse completely. Switch off the heater blade. While it is still hot, clean thoroughly with emery paper or a wire brush ready for the next joint. Unclamp the jig and carefully remove the waterstop. Do not flex the joint until it has cooled. The joint is now complete. When cold, test it by flexing the waterstop several times.

MASTERFLEX[®] AQUASTOP

T-Piece

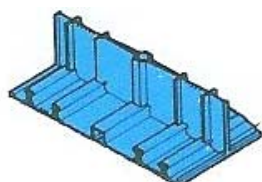

T-Piece

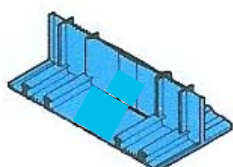

If a composite edge mitre is needed, simply cut off one of the horizontal legs.

Supply / estimating

MASTERFLEX AQUASTOP profiles are supplied in 15 Metre rolls.

Flat intersections are supplied with a leg length of 250mm from centreline.

Edge intersections are supplied with 100mm legs.

Health and safety

Hot welding of PVC produces hydrochloric acid fumes, which in confined spaces may exceed the minimum TLV of 5 ppm. Therefore forced ventilation must be provided or a suitable respirator used.

In open site applications, it is not considered that any health dangers exists.

05/2006 BASF_CC-UAE

* Properties listed are based on laboratory controlled tests.

Whilst any information contained herein is true, accurate and represents our best knowledge and experience, no warranty is given or implied with any recommendations made by us, our representatives or distributors, as the conditions of use and the competence of any labour involved in the application are beyond our control.

As all BASF technical datasheets are updated on a regular basis it is the user's responsibility to obtain the most recent issue.

BASF Construction Chemicals UAE LLC

P.O. Box 37127, Dubai, UAE

Tel: +971 4 8090800

Fax: +971 4 8851002

www.basf-cc.ae

